

**NOTICE TO PERSONS RECEIVING THIS DRAWING AND/OR TECHNICAL INFORMATION**  
 This information is subject to the following understanding and agreement. Columbus McKinnon Corporation reserves its proprietary rights in all material and information depicted or disclosed hereon. This drawing and/or technical information is issued in confidence for engineering information and may not be reproduced in whole or in part nor used in any way for the manufacture or production of anything referred to or depicted hereon without the prior express written consent of Columbus McKinnon Corporation. Furthermore, this drawing and/or technical information shall not be modified or misused and shall not be copied, reproduced or disclosed to others without the prior express written consent of Columbus McKinnon Corporation. This drawing and/or technical information is and shall be returned to Columbus McKinnon Corporation upon demand or upon completion of the purpose for which lent. The recipient hereof agrees to hold this drawing and/or technical information in strict confidence. By accepting this drawing, the recipient agrees to all of the foregoing terms and conditions.

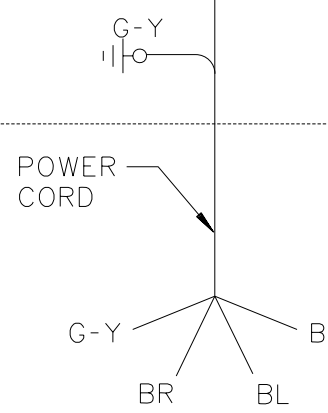

**CM**® COLUMBUS MCKINNON CORPORATION  
 INDUSTRIAL PRODUCTS DIVISION  
 140 JOHN JAMES AUDUBON PARKWAY  
 AMHERST, NEW YORK 14228-1197

WIRING DIAGRAM-LODESTAR HOIST  
 MODELS J, L, & R, 1HP  
 DIRECT CONTROL UNIT  
 415/220-3-50  
 STROMAG BRAKE ONLY

DATE 1-09-07 B - 1F - 11279