



# Carbon Cub From LTM



The Carbon Cub is a compact, portable, plug and play mini hoist system.

It is suitable for a variety of lifting applications in theatre, broadcast, museum, sporting, worship and retail venues.

It is especially designed to raise and lower lights, scenic elements, projectors or banners.

The Cub is matt black with black lifting cables and weighs only 41Kg.

The cub's low profile maintains a 89 mm overhead clearance.

Individual or multiple hoists may be selected for simultaneous operation.

### Specification

Travel Speed:	4.3 m/min
Lifting Height:	7.5 m
Lifting Capacity:	136 Kg
Self Weight:	41 Kg

- With self locking helical gears driving a shaft with two rope drums
- Right and left hand grooved drum winding – prevents lateral movement
- With limit switches and over travel protection
- With low voltage controls and remote pendant facility with the ability to operate through a multiple hoist control system
- Power Supply: 400V, 3Ph, 50Hz or 220V, 1Ph, 50Hz

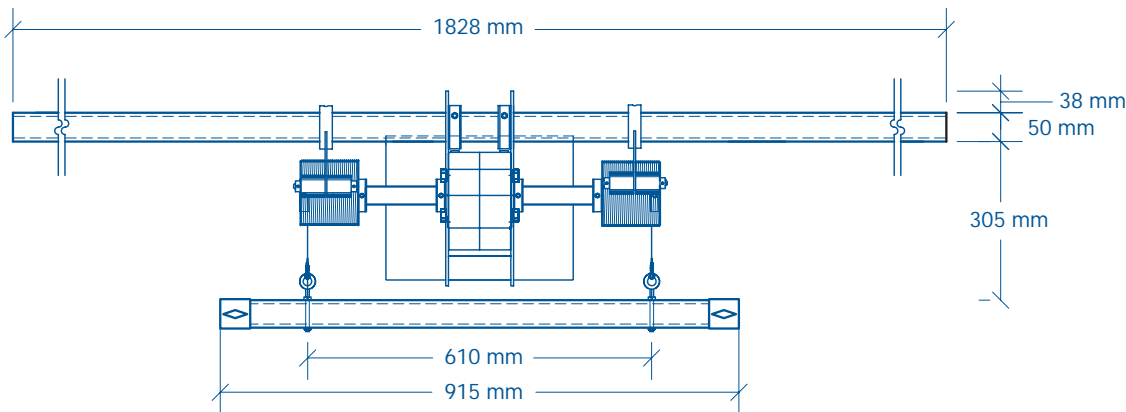
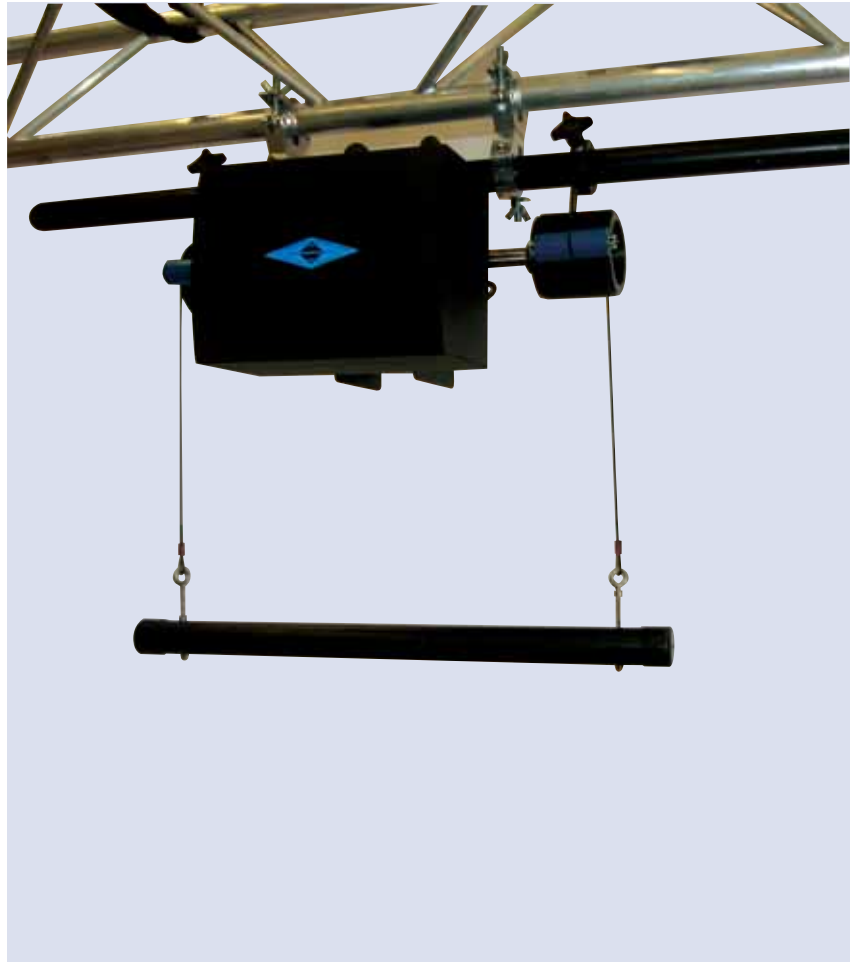

FRONT ELEVATION

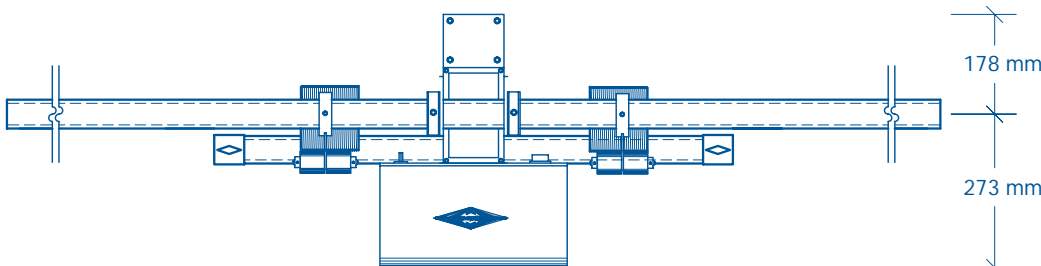

TOP VIEW



UNIT 6, APPIN ROAD  
 ARGYLE INDUSTRIAL ESTATE,  
 BIRKENHEAD  
 MERSEYSIDE  
 CH41 9HH  
 UK

TEL: +44 (0)151-649-0467  
 FAX: +44 (0)151-649-0099

WWW.LIFTTURNMOVE.CO.UK  
 SALES@LIFTTURNMOVE.CO.UK